



"Building the Perfect Ride"

FRAME LOCKS INSTALLATION INSTRUCTIONS

**FOR
HONDA CIVICS 1992 – 1995
Revision date: 5/2/05**

**CONCEIVED, DEVELOPED, DESIGNED & MANUFACTURED
BY**

KÖRBACH PERFORMANCE

969 G Edgewater Boulevard, Unit # 248, Foster City, California 94404

www.korbachperformance.com

customer_srvc@korbachperformance.com

1-866-8KORBACH

1-866-856-7222

650-523-4700 (Fax)

!!!!!! READ THIS FIRST !!!!!

SAFETY ITEMS TO FOLLOW

- **JACK STANDS** If you need to jack the car up, you must use jack stands to prevent the car from accidentally falling down and injuring or even killing someone. **Do NOT take any chances!**
- **SAFETY GLASSES** You must wear safety glasses especially when drilling. The burrs that are generated from drilling are small, but extremely sharp and can cause injury to an unprotected eye. Do not underestimate this hazard!
- **GLOVES AND LONG SLEEVED SHIRT** It is a good practice to wear gloves and a long-sleeved shirt when drilling. The burrs are sharp and hot and can sting your hands and arms.

FRAME LOCKS POTENTIAL DIFFICULT INSTALLS

- **FACTORY RESONATOR** – Some Civics have a resonator. If you have one, it will have to be removed in order to install the Frame Locks. Some people will remove resonators to create a more aggressive intake sound.

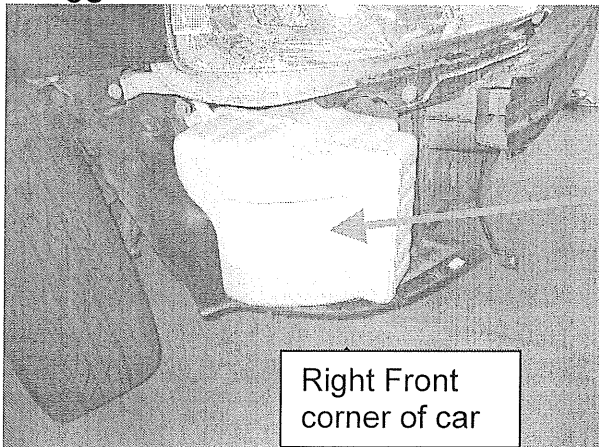

- **COLLISION** – If your car has been in a front end collision and was repaired, the Frame Locks may have difficulty lining up. You can determine this by following steps 1-13. If it doesn't fit contact us on info@korbachperformance.com.

INSTALLATION CRITICAL STEP – KEY POINT !!!

- Please be sure to **follow step 11. correctly.** If bracket is not positioned in the “GOOD” location, the holes will not be drilled in the correct location. This is a very easy process, but should not be overlooked! The rest is easy and should take 1 -2 hours to complete.

!!!!!! READ THIS FIRST !!!!!

DISCLAIMER

- 1) All products sold by Körbach Performance are intended for exclusive use in off-road racing applications in sanctioned, closed-course competition. Federal and/or state laws may prohibit the use of modified vehicles on public roads and highways. Auto racing is a hazardous sport and can result in property damage, serious bodily injury, and/or fatality.
- 2) The use of seatbelts greatly reduces the risk of serious injury in the event of a collision. Upon installation of Körbach Performance products, all vehicle occupants agree to wear seatbelts at all times.
- 3) I will use all necessary safety precautions while installing Frame Locks on my vehicle and/or others' vehicles. These precautions include, but are not limited to use of safety glasses, jack stands, and gloves. Should injury and/or fatality occur during the installation process, I will not hold Korbach Performance, Korbach Structures, nor its officers, directors, shareholders, consultants, or any other of its past, present, and/or future associates liable for any damages.
- 4) I will not hold Korbach Performance, Korbach Structures, nor its officers, directors, shareholders, consultants, or any other of its past, present, and/or future associates liable for any damages, injuries, and/or fatalities incurred from the use of their products. I agree that I will not seek damages in any form, including by means of lawsuit. Should litigation or arbitration result, I agree that it will be settled in San Mateo County, California.
- 5) Körbach Performance has researched, developed, designed, or tested their products for safety including, but not limited to, valid on-road vibration testing to ensure against false air bag deployment. I understand that not all real-world driving conditions can be simulated, and I assume all liability with the purchase and/or use of any Körbach Performance product.
- 6) Any structural alterations to a vehicle such as lowering the suspension, chassis bars, H braces, traction bars, tie bars, strut bars, and Frame Locks may result in the following:
 - a) Voided manufacturer's warranty resulting in purchaser's sole responsibility for the cost of, and possible increase in cost of, vehicle repair in the event of a collision.
 - b) Possibly some adverse effects in crash performance of the car resulting in increased forces exerted to the driver and occupants, which may result in an increased risk of injury or the likelihood of fatality to driver, passengers, and/or bystanders, in the event of an accident.
 - c) Deployment of air bags in conditions not originally intended by the manufacturer.
- 7) I will remove the Frame Locks upon making the decision to sell or transfer ownership title of my vehicle. Should I decide to leave the Frame Locks attached, I will inform the new owner of all risks associated with Frame Locks. I will share this disclaimer with the new owner prior to sale, or will direct them to www.korbachperformance.com to read the disclaimer online.
- 8) No salesman, officer, agent, nor representative of Körbach Performance is authorized to waive this disclaimer and limitation of damages. Further, no representation, promise, description of goods, or affirmation of fact made by any salesman, officer, agent, or representative of Körbach Performance shall be effective to any extent whatsoever to waive or modify this disclaimer and limitation of damages.

PHOTO OF FRAME LOCK INSTALLED TO CAR

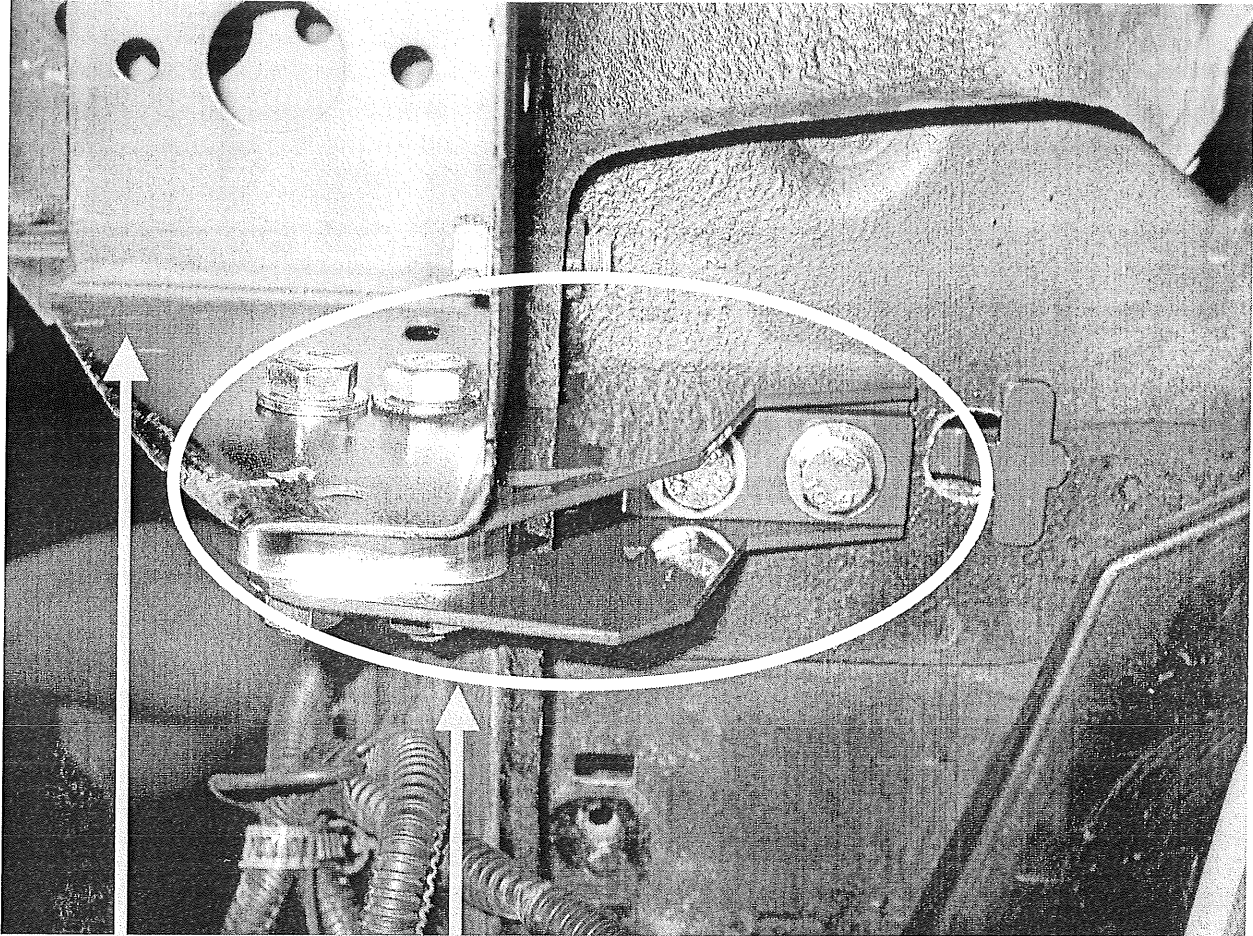

Left Frame Lock

Front bumper beam

(VIEW OF FRONT LEFT CORNER OF CAR)

TOOLS YOU WILL NEED

- Safety glasses
- Gloves (to prevent burrs when drilling)
- Long sleeve shirt (**Recommended** to prevent burrs when drilling)
- 3/8" ratchet
- 3" extension
- 6" extension
- 8 mm socket
- 10 mm socket
- 13 mm socket
- 13 mm wrench
- Drill (corded drill is fastest)
- Phillips screw driver
- Small flat tip screwdriver
- Drill bit 5/32"
- Drill bit 3/8"
- Drill bit 5/8" (3/8" shank recommended to fit common 3/8" chuck)

TOOLS YOU MAY NEED

If your car has been lowered, the following may be needed to fit the drill underneath the bumper beam.

- Jack
- Jack stands

SAFETY WARNING !!!!!

If car needs to be jacked up, you must use jack stands to prevent possibility of car accidentally dropping down causing injury or even death.

PARTS YOU SHOULD HAVE

Note: Drill bits are not included but can be purchased separately

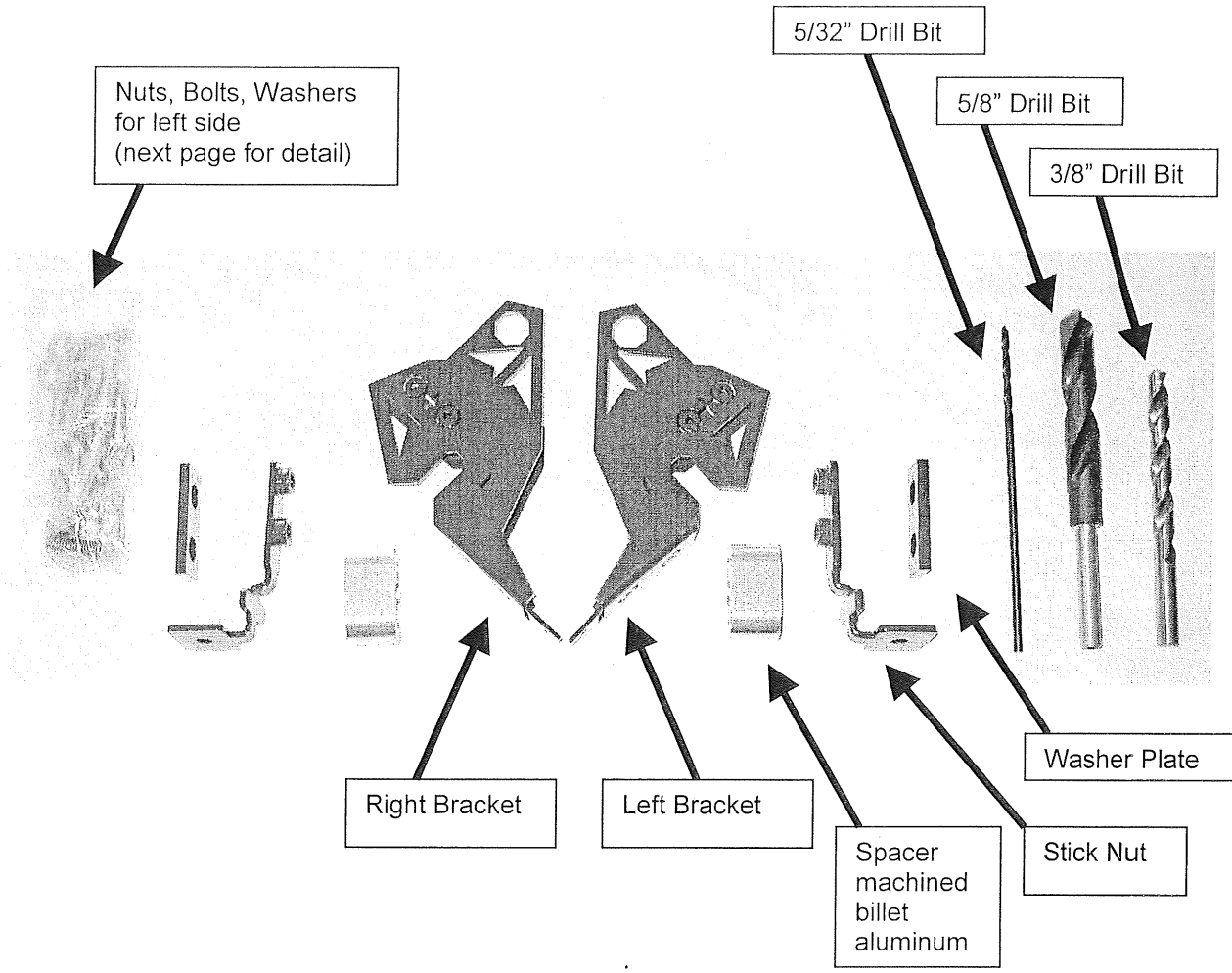

PARTS YOU SHOULD HAVE

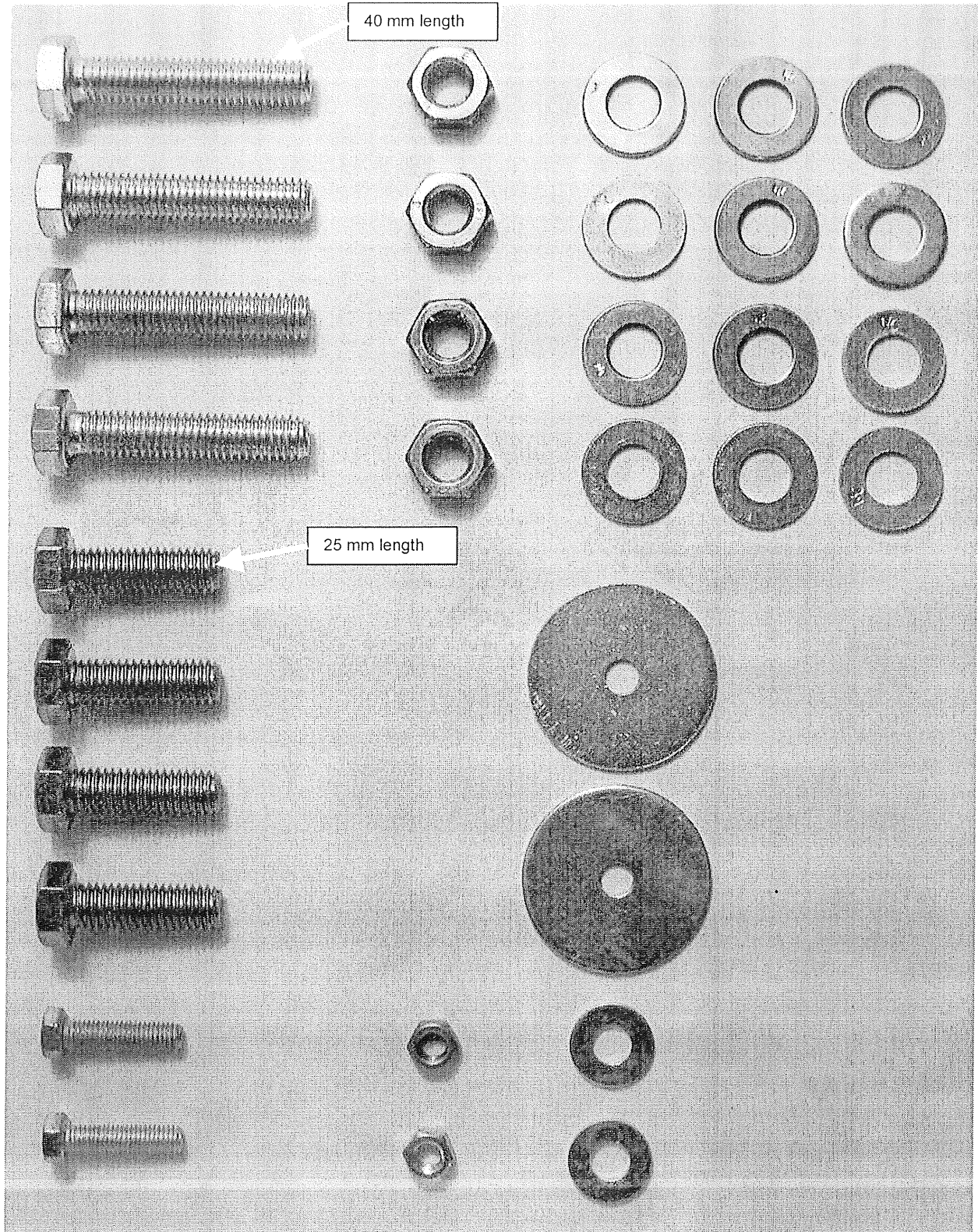

REMOVE BUMPER FASCIA

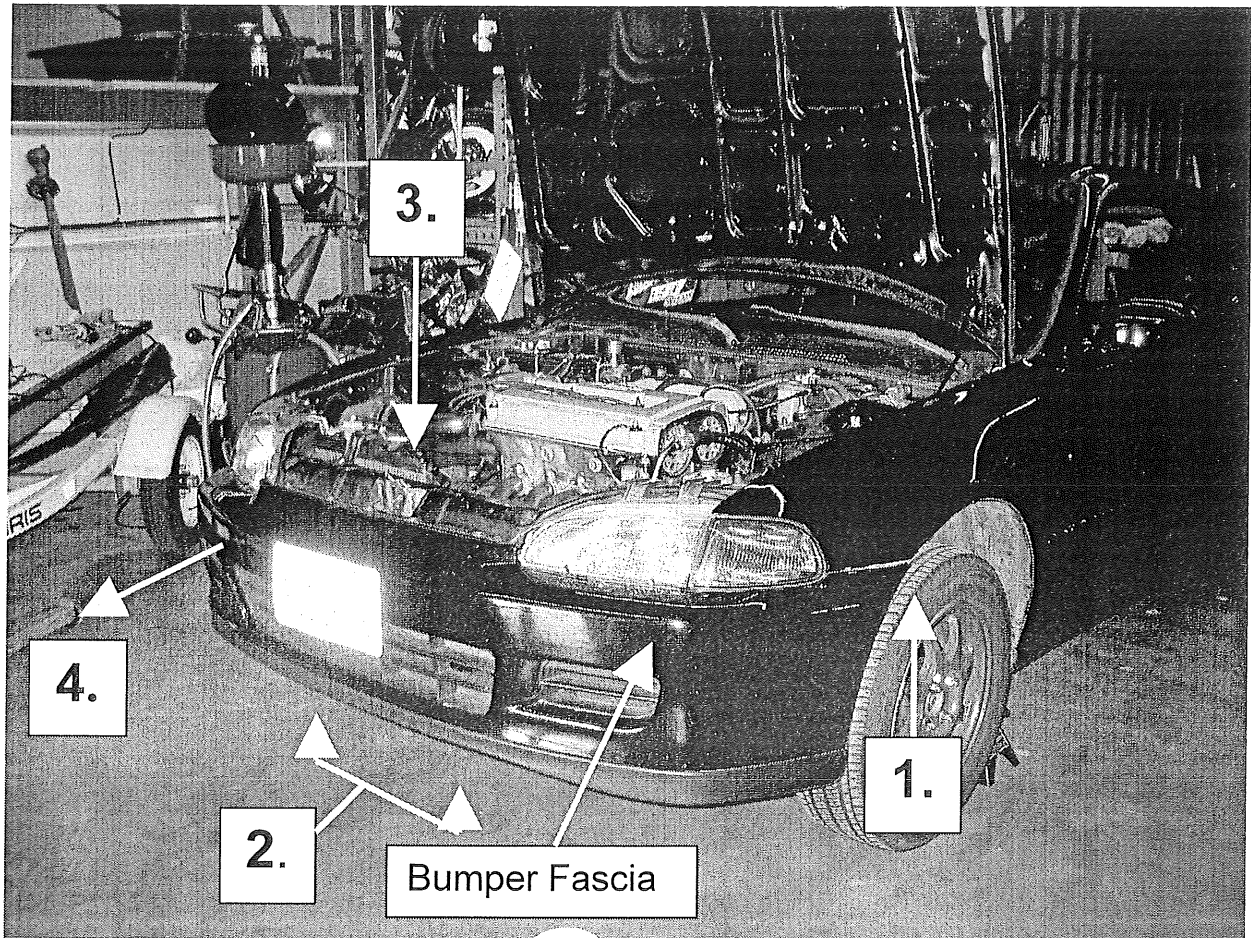

1. Remove screw from bumper fascia. You may need to turn the steering wheel for better access.
2. Remove (2) bolts (10mm hex) on the underside of the bumper fascia.
3. Remove (5) bumper clips using a small flat tip screw driver
4. Remove bumper fascia.

REMOVE BUMPER BLOCK

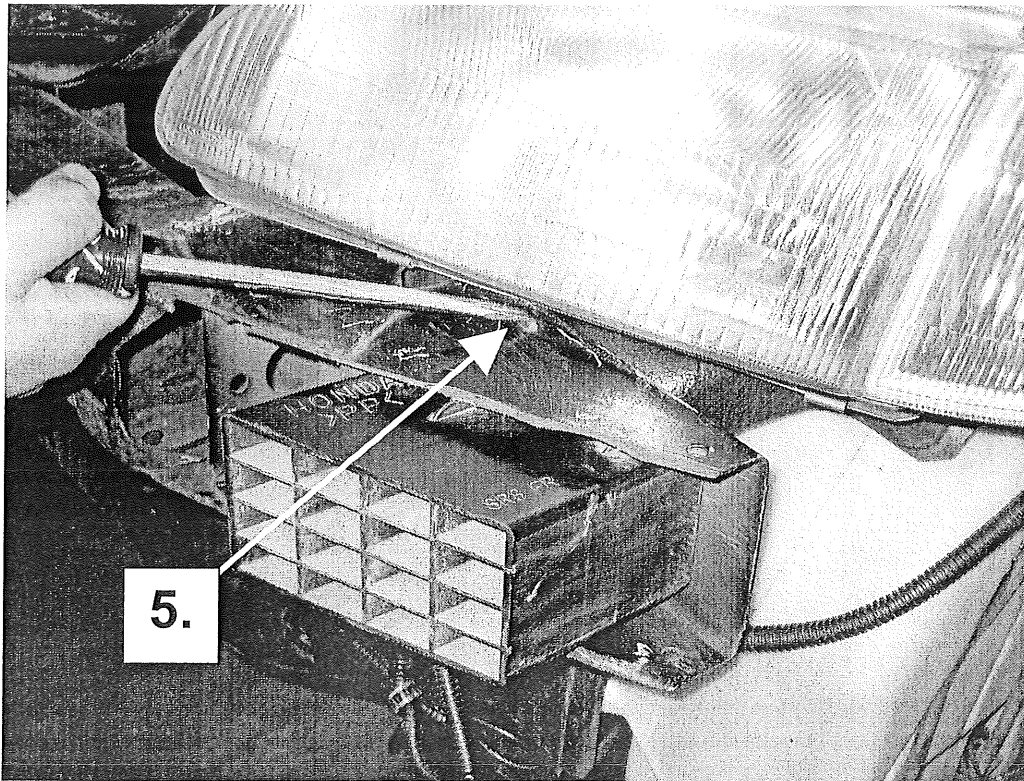

5. Press in tab with a screwdriver.
6. Remove (pull out) block.

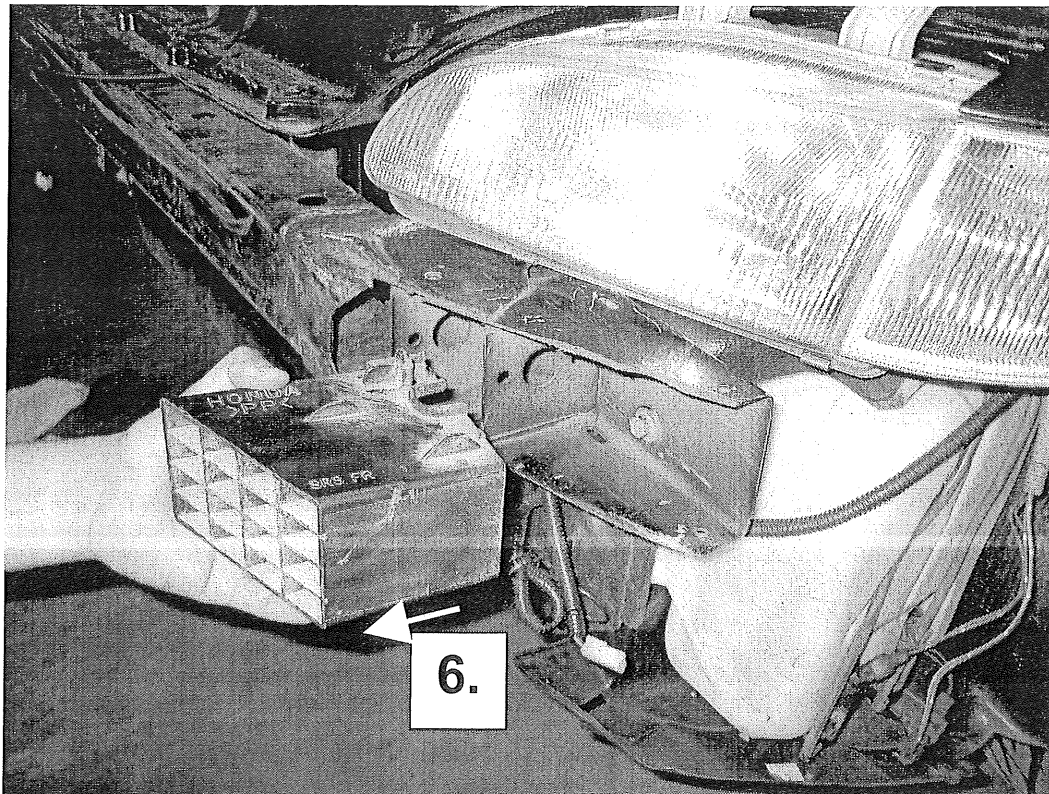

LOWER WASHER BOTTLE

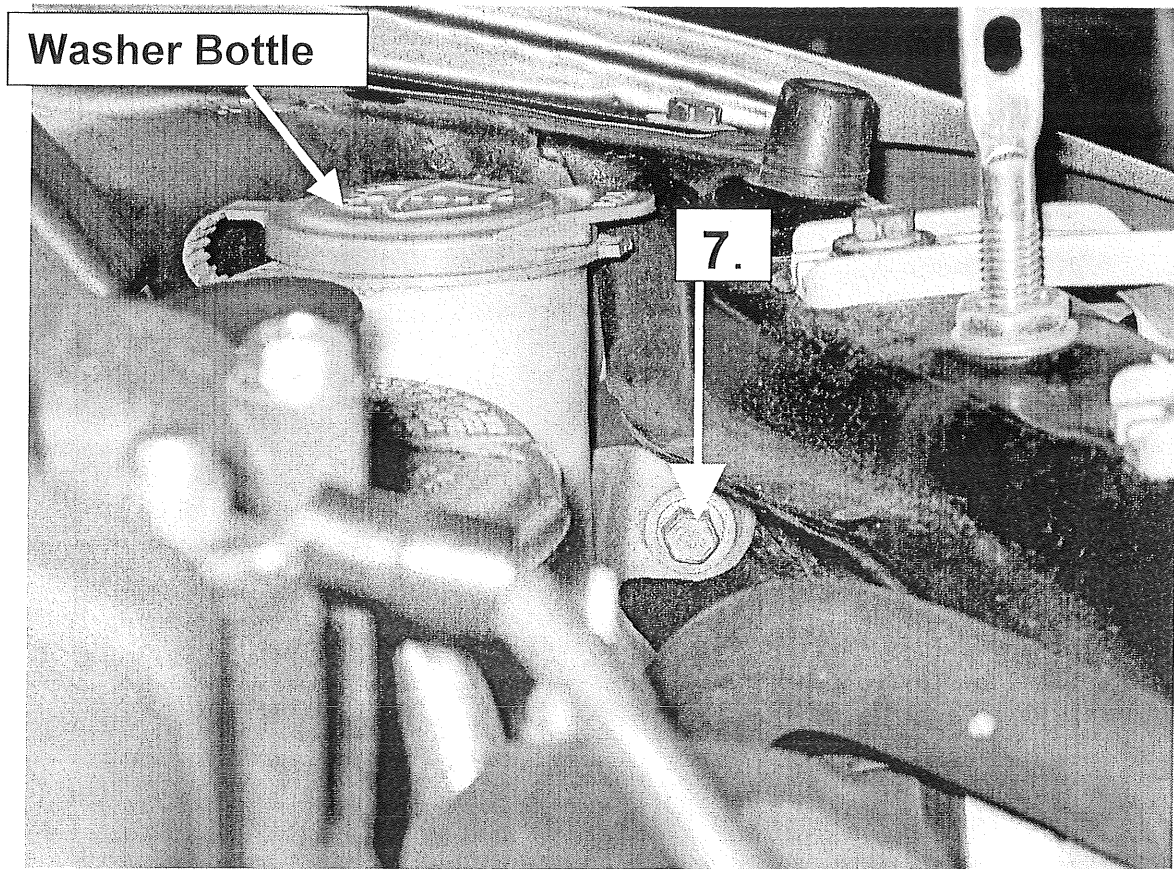

7. Remove bolt (10 mm hex).

LOWER WASHER BOTTLE

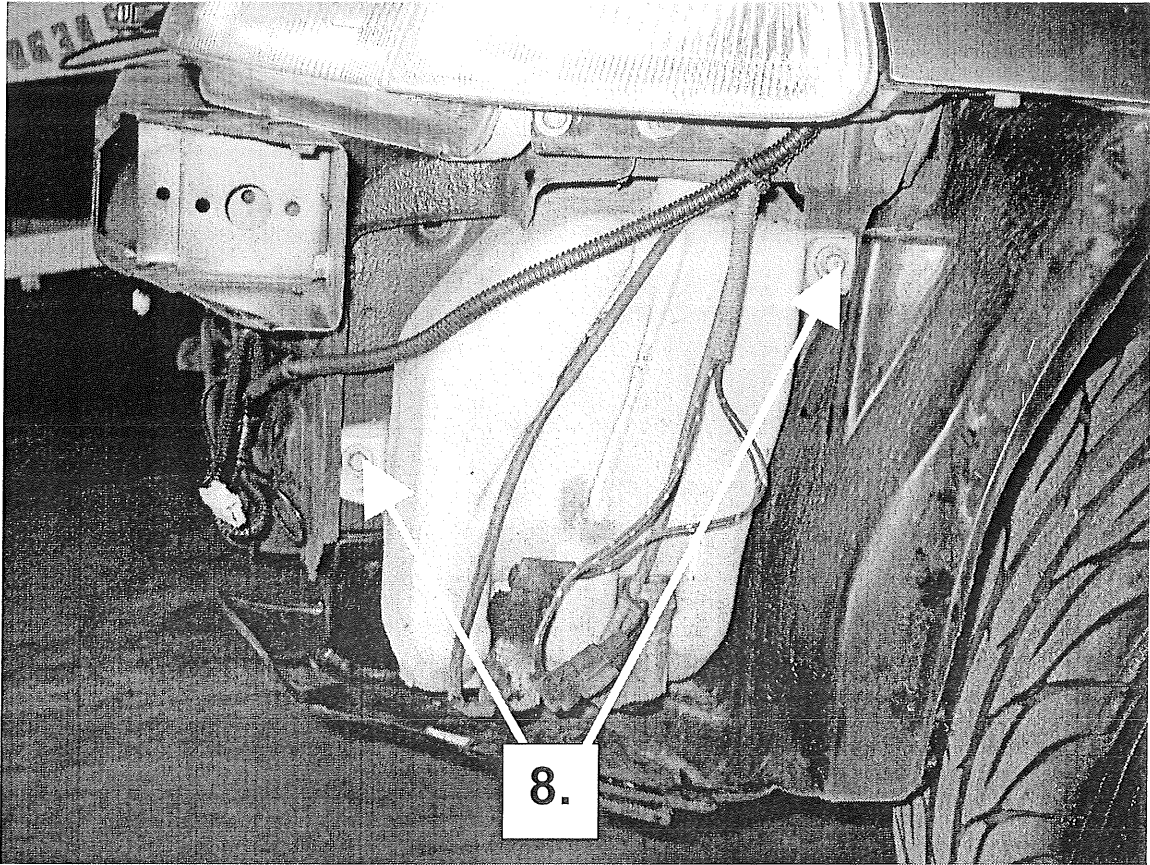

8. Remove (2) bolts (10 mm hex).

LOWER WASHER BOTTLE

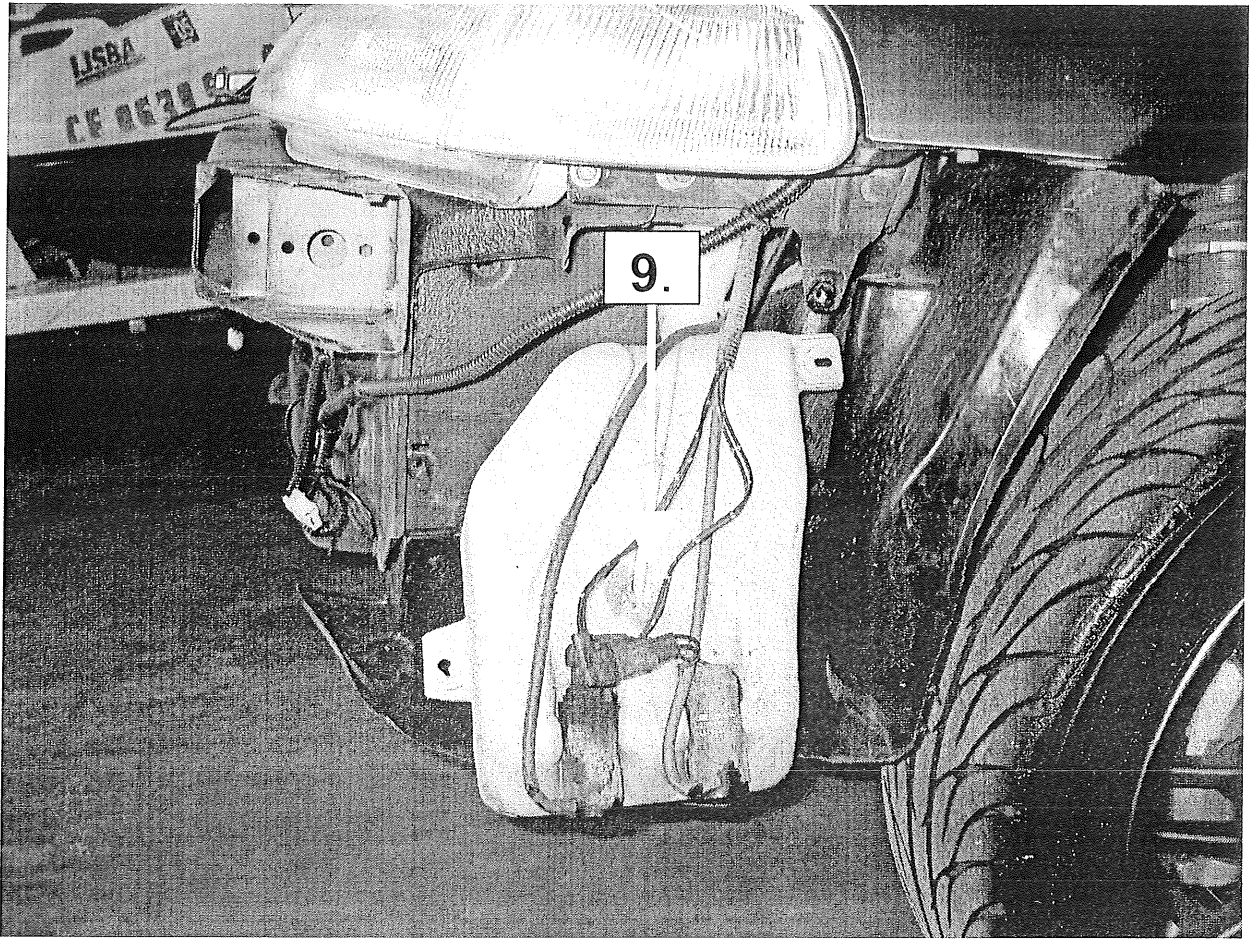

9. Pull washer bottle down about 8 - 10 inches.

TEMPORARILY INSTALL BRACKET

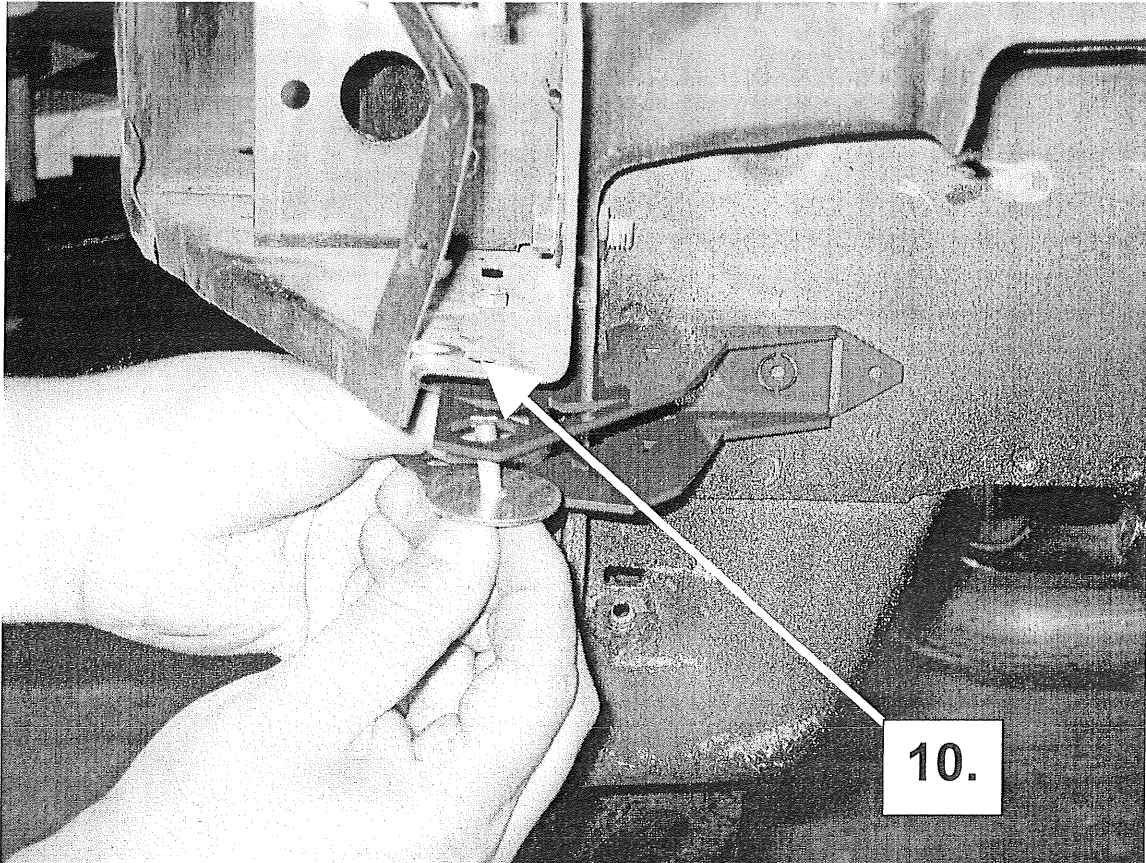

10. Insert bolt (8 mm hex) through bracket and hole.

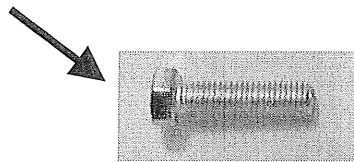

Do not fully torque the bolt until reading step 11 on the next page.

TEMPORARILY INSTALL FRONT BRACKET

VERY IMPORTANT- READ THIS CAREFULLY !!

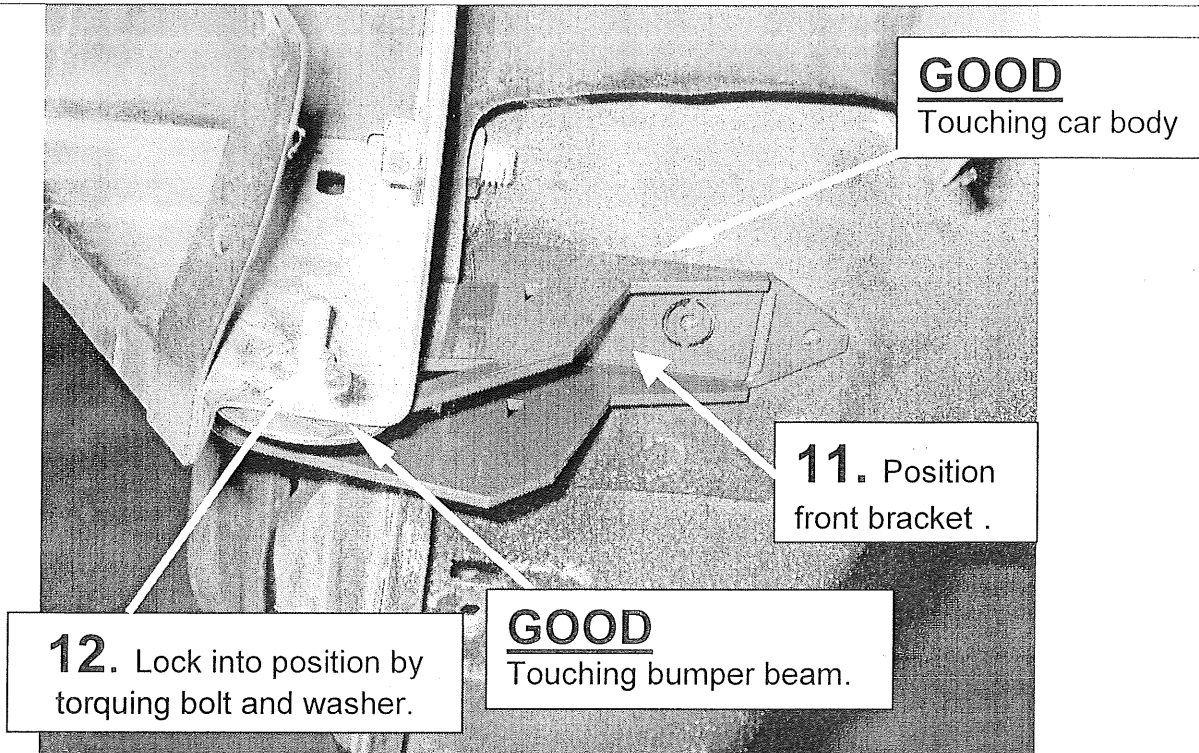

11. Position the bracket such that it is touching the front bumper beam and the body of the car.
12. Torque the bolt (13 mm hex) and washer tight enough to hold bracket firmly.

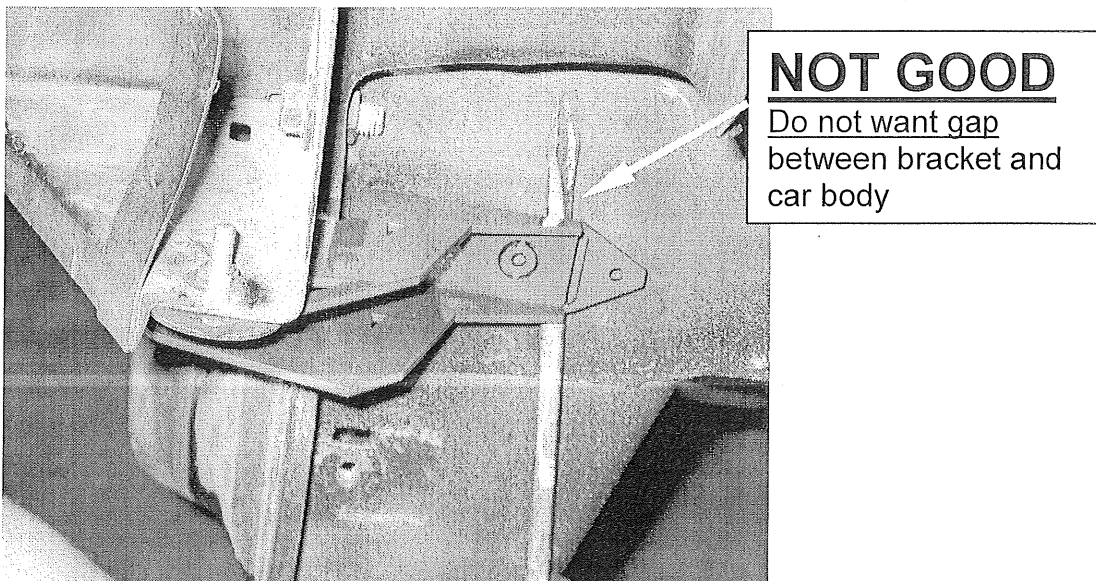

TEMPORARILY INSTALL FRONT BRACKET

Q: WHY IS POSITIONING OF FRONT BRACKET IMPORTANT?

A: *Because the location of the bracket will determine the location of the drilled pilot holes, which will determine the location of the bolt holes. If the gap is too big, it may be difficult to achieve the best possible fit of parts.*

13. Repeat steps 10 – 12 on right side of car in order to insure that holes line up.

DRILL (2) PILOT HOLES TO BUMPER BEAM

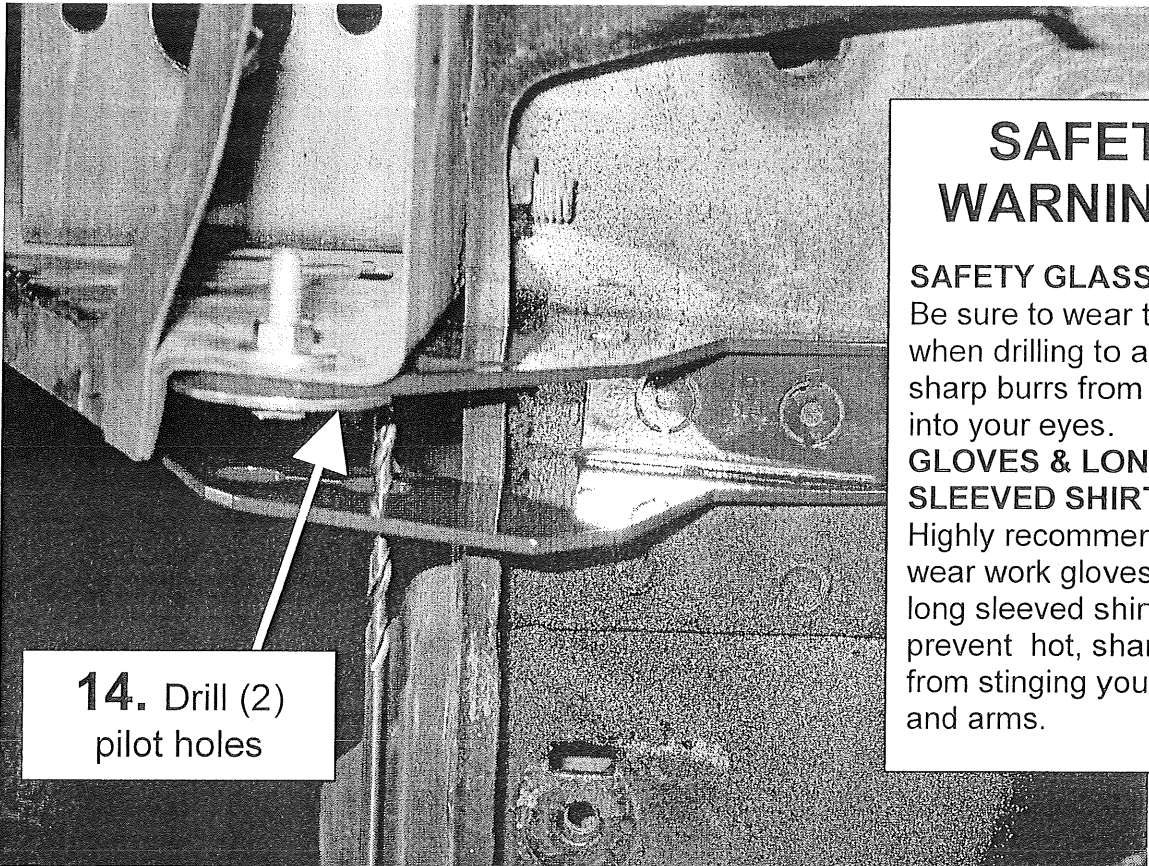

14. Drill (2)
pilot holes

SAFETY WARNING !!

SAFETY GLASSES

Be sure to wear them when drilling to avoid sharp burrs from getting into your eyes.

GLOVES & LONG SLEEVED SHIRT

Highly recommended to wear work gloves and long sleeved shirt to prevent hot, sharp burrs from stinging your hands and arms.

14. Drill (2) holes with the 5/32" (smallest) drill bit.

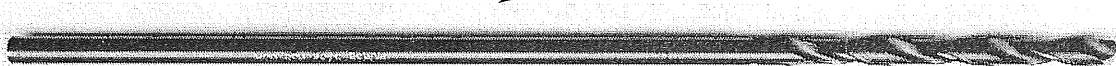

View looking up at the bumper.

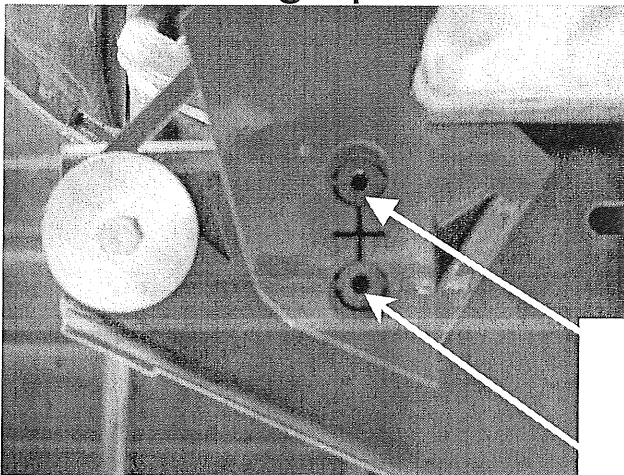

DRILLING TIP.

When drilling, keep drill bit perpendicular to surface. Exert low/medium force. With fresh sharp drill bits and a corded power drill, it should take about 30 seconds to drill each hole. Let the speed of the drill do the work.

14. Insert drill bit through these small holes in the bracket & drill.

DRILL (3) MORE PILOT HOLES

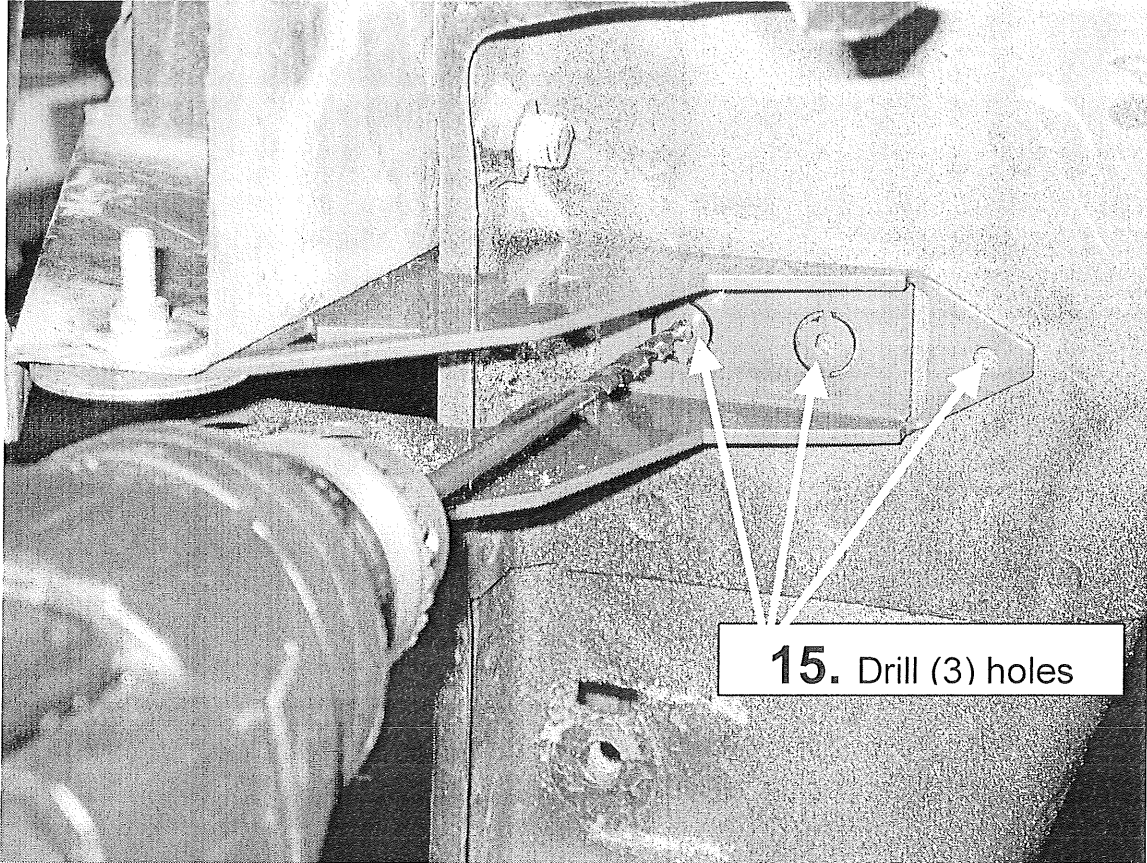

15. Insert drill bit through the small holes in the brackets and drill (3) holes with the 5/32" (smallest) drill bit.

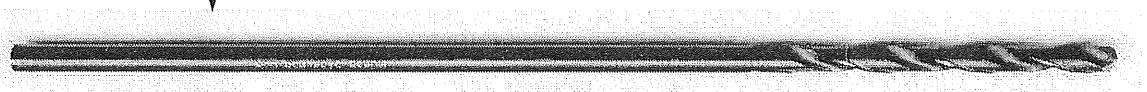

DRILLING TIP.

When drilling, keep drill bit perpendicular to surface. Exert low/medium force. With fresh sharp drill bits and a corded power drill, it should take about 30 seconds to drill each hole. Let the speed of the drill do the work.

PHOTO OF PILOT HOLES

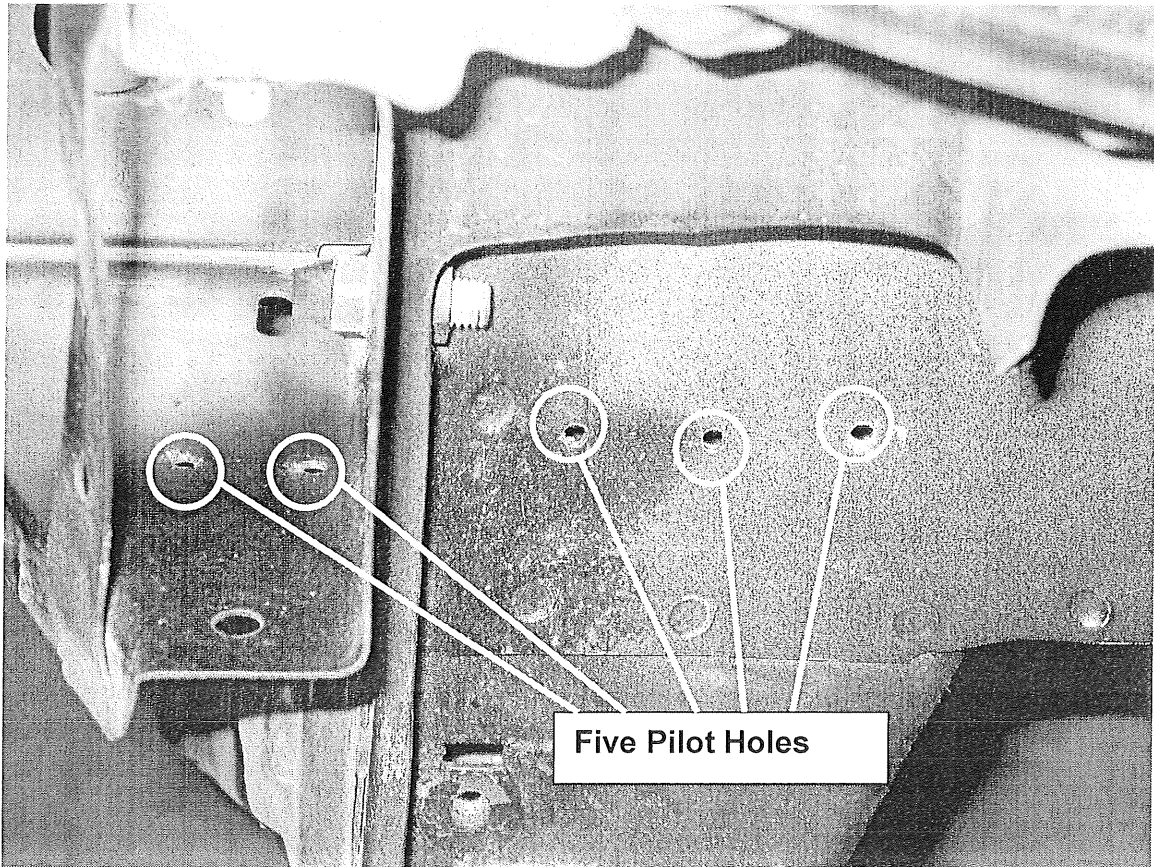

Removing the bracket should reveal these holes.

DRILL (4) 3/8" HOLES & (1) 5/8" HOLE

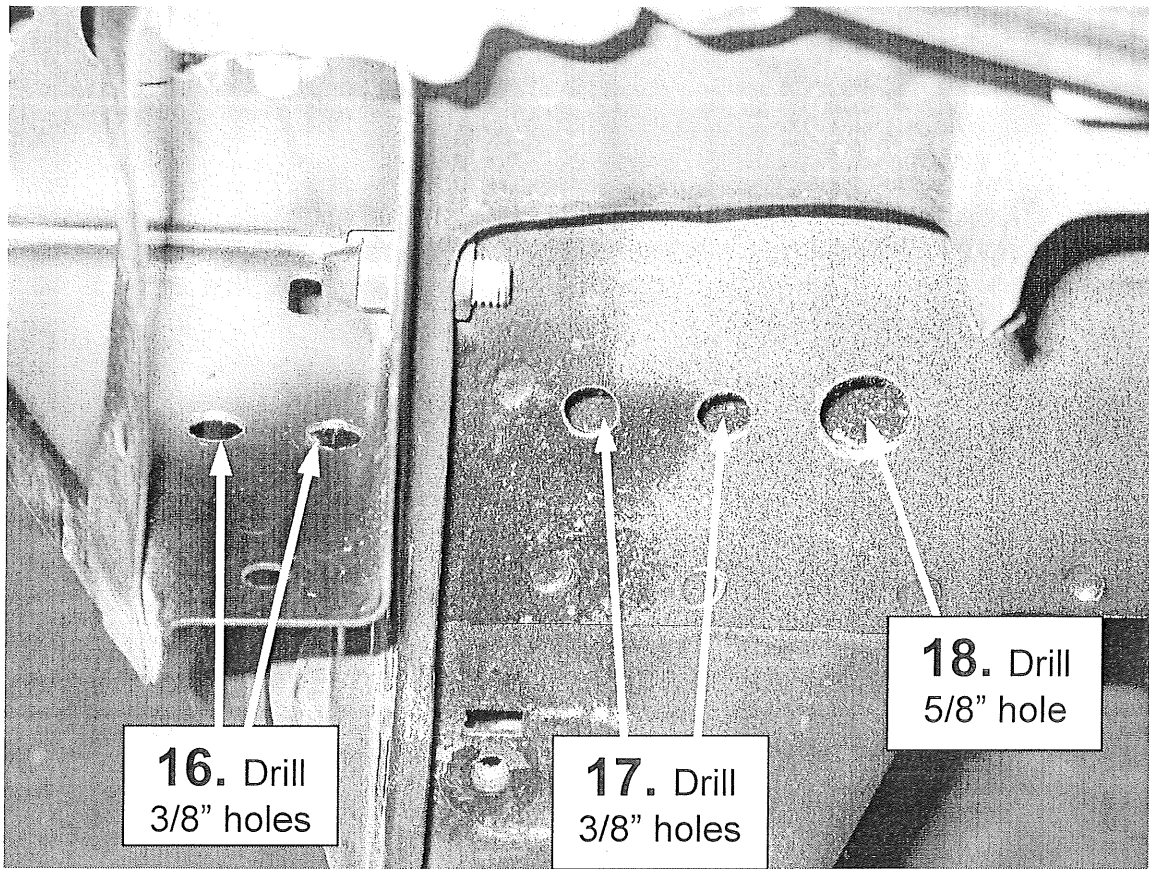

16. After removing the bracket, drill through the 5/32" pilot holes in the bumper beam using the 3/8" (medium) drill bit.



17. Drill through the 5/32" pilot holes in the body of the car using the 3/8" (medium) drill bit.

TIP FOR DRILLING LARGER HOLES. Exert low/medium force. When hole is almost drilled through, exert just a light push force. Let the speed do the work. With fresh sharp drill bits, it should take about 30 - 40 seconds to drill each hole.

DRILL (4) 3/8" HOLES & (1) 5/8" HOLE

18. Drill through the pilot hole using the 5/8" (large) drill bit.

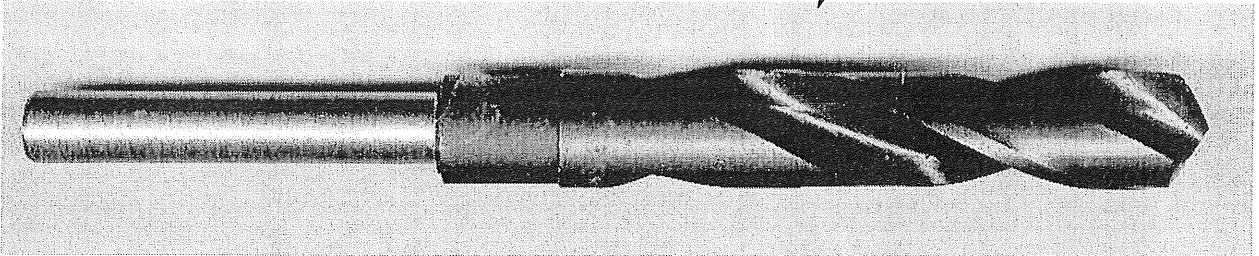

REMOVE "BREAK AWAY" PIECES

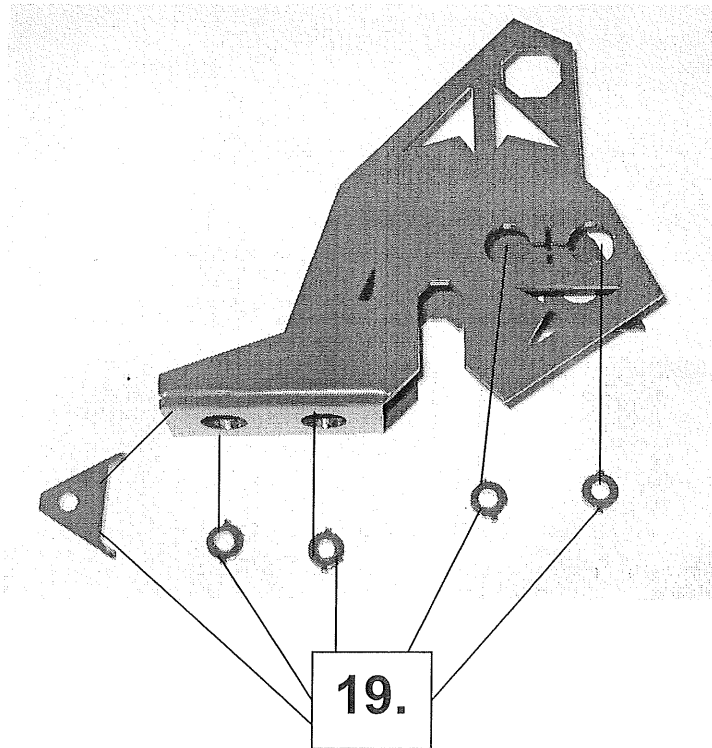
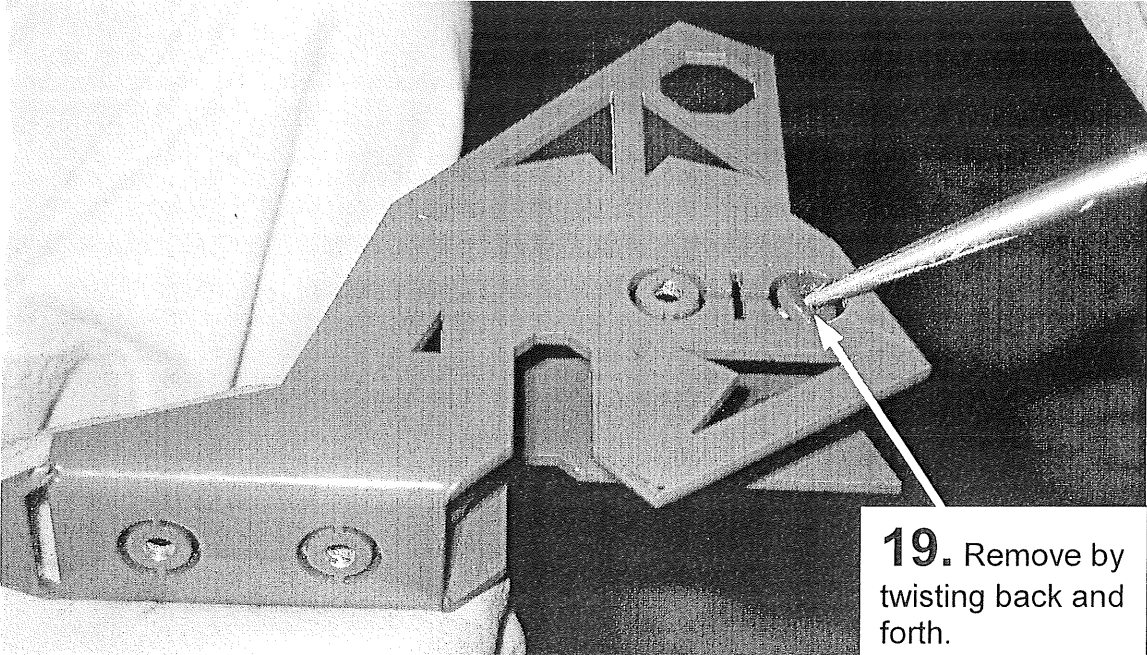

19. Using a small screw driver or nail, remove the (5) break-away pieces by twisting the round "slug" back and forth.

INSERT SPACER

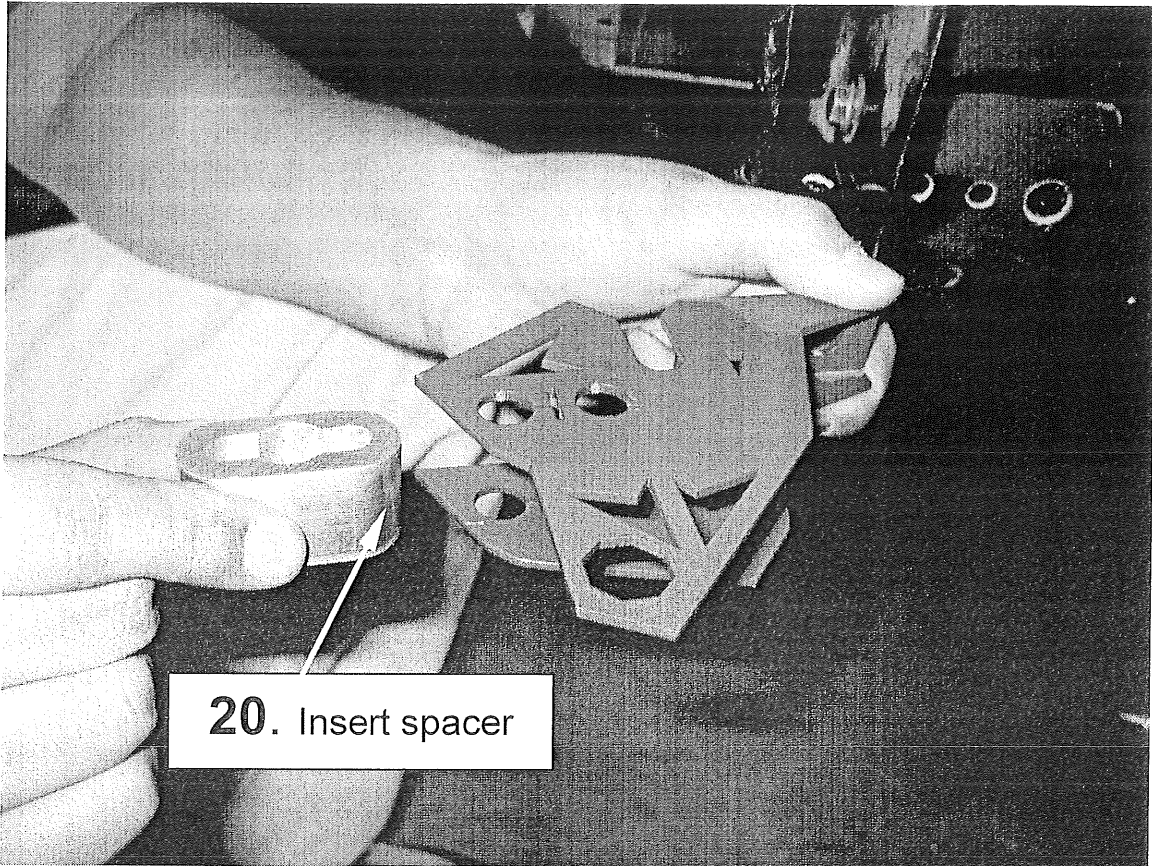

20. Insert and align aluminum spacer with the holes in the bracket.

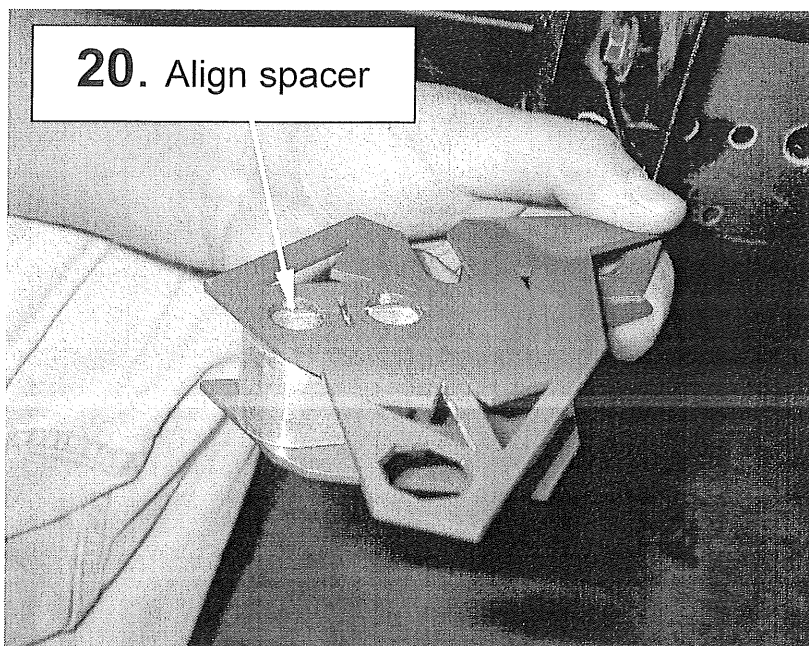

INSTALL BRACKET

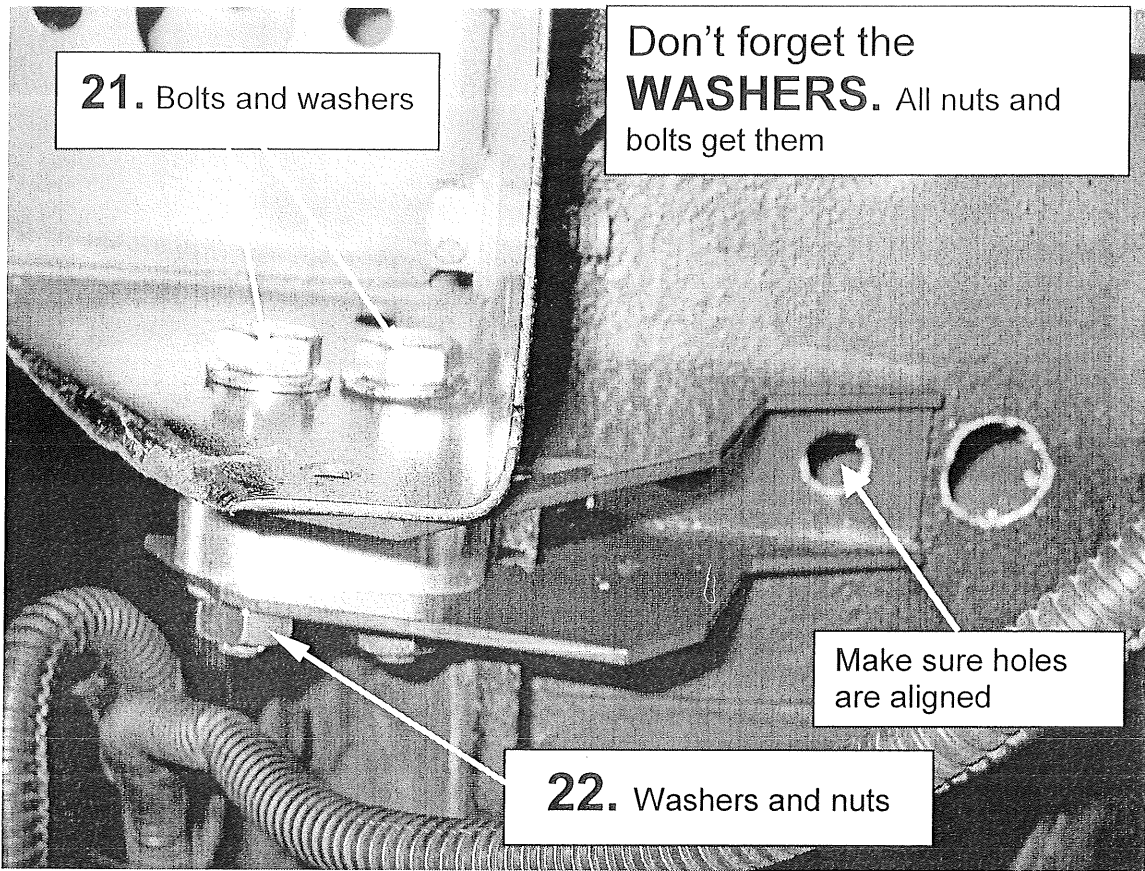

21. Install bracket on to bumper beam. Insert two bolts (13 mm hex, length = 40 mm) pointed downward and washers.

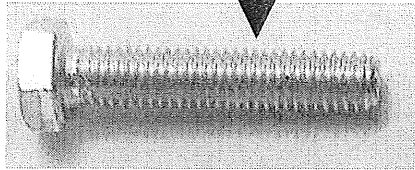

22. Insert (finger tight) washer and nut to each bolt in step 21. **Make sure that the washers and nuts go on the bottom side of the bracket.**

INSTALL STICK NUTS

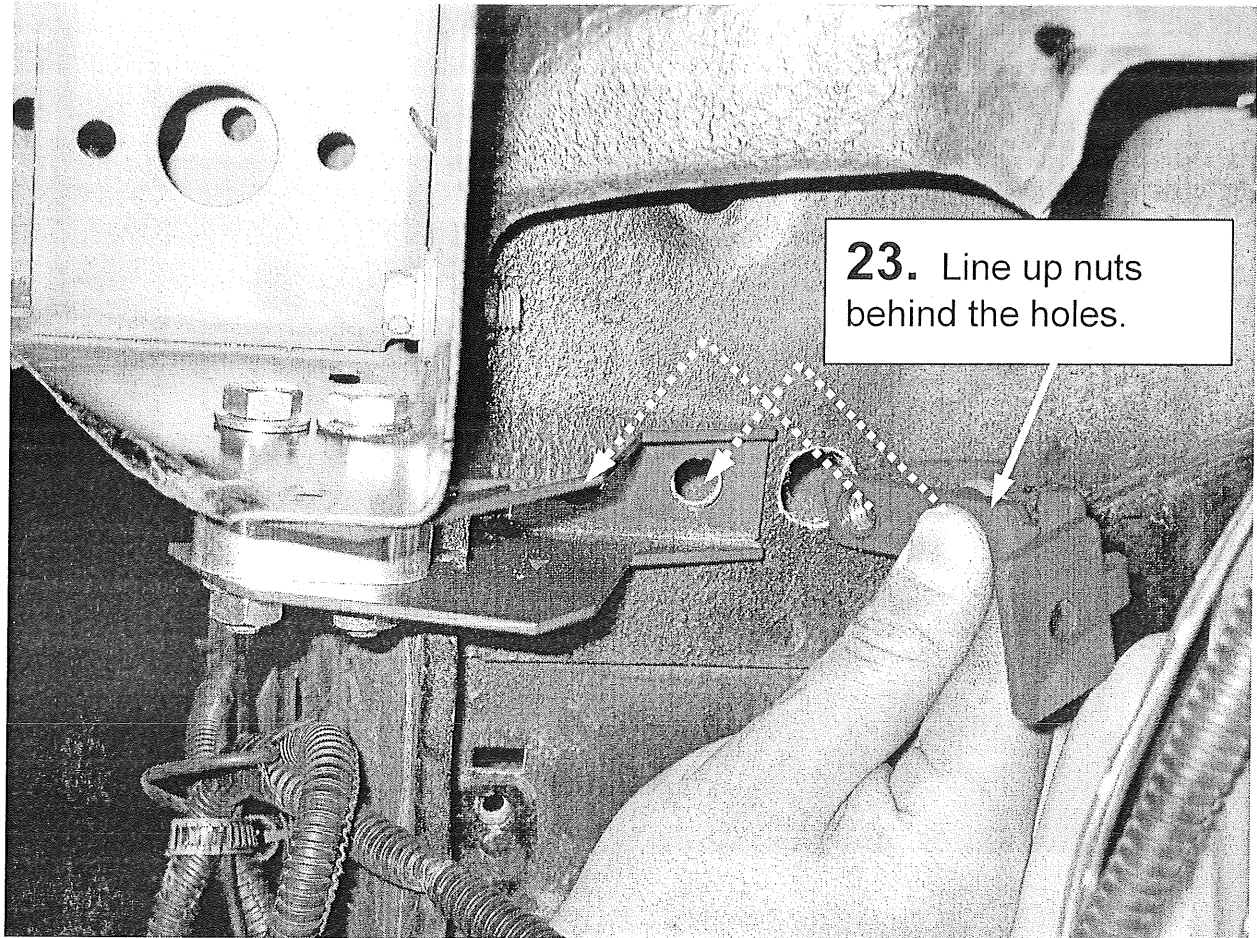

- 23.** Insert the stick nuts through the 5/8" hole. Line up nuts with the holes of the car body and the bracket.

INSTALL WASHER PLATE

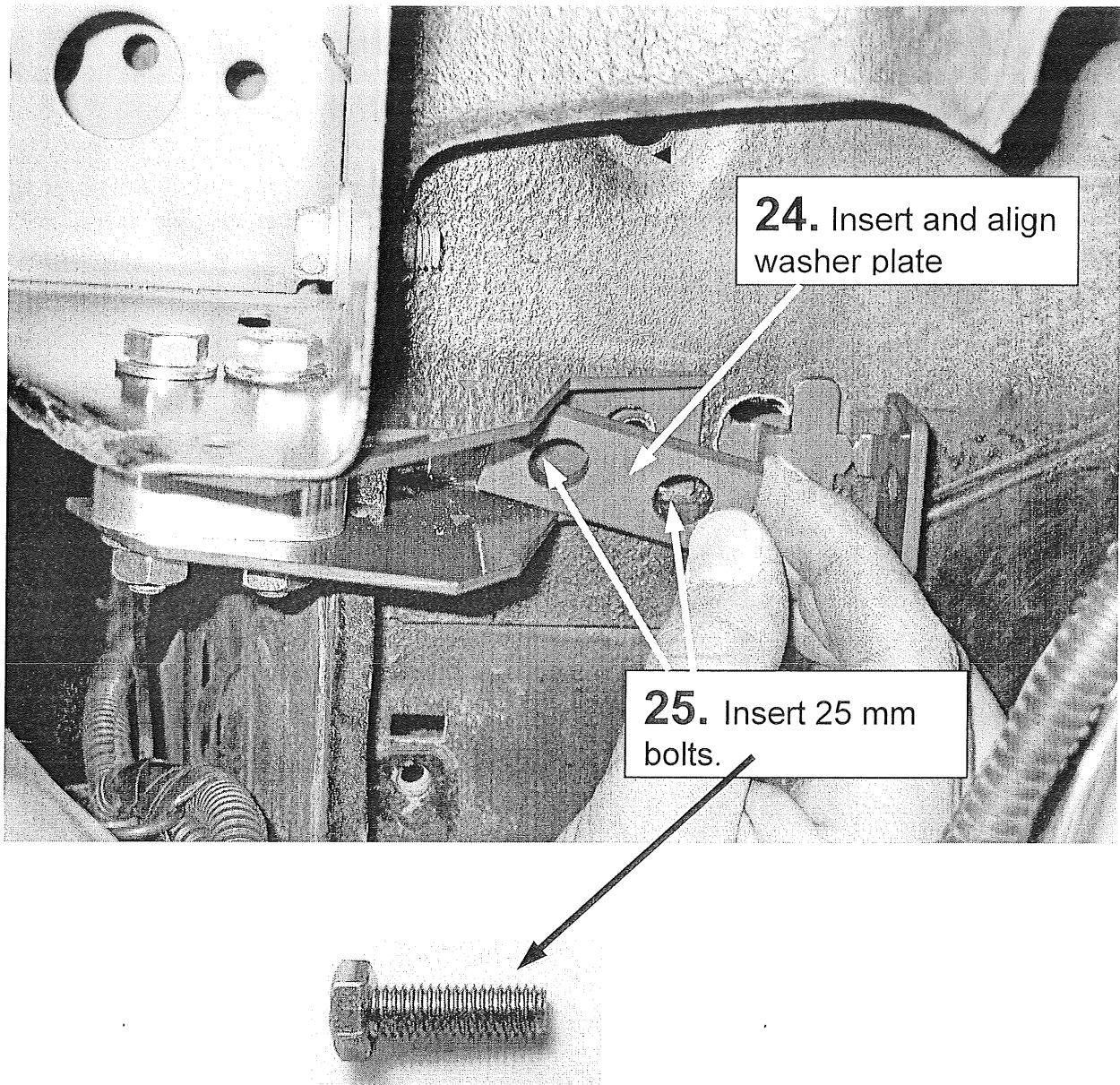

24. Insert and align the washer plate with the holes.

25. Insert (finger tight), two bolts (13 mm hex, length = 25 mm) through the washer plate, bracket, and in to the two nuts on the inserted stick nut.

TORQUE DOWN ALL NUTS & BOLTS

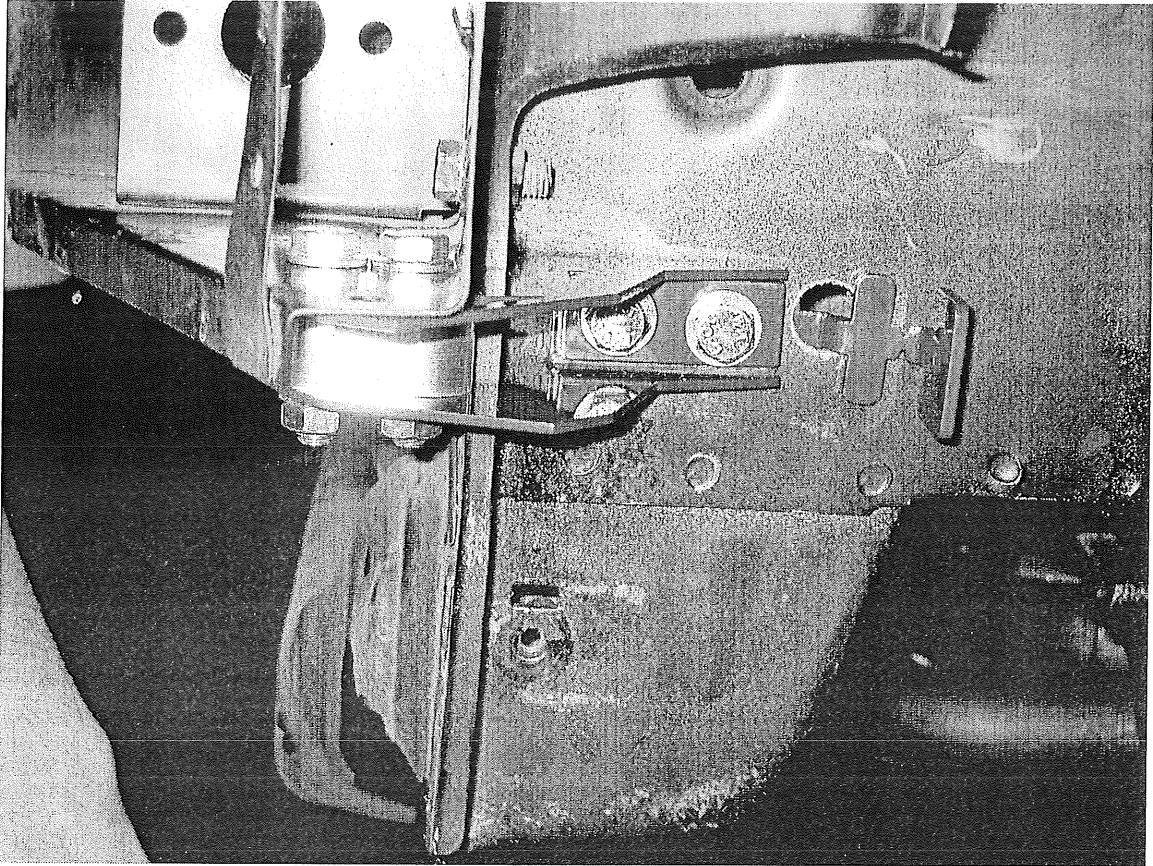

26. Torque down all of the nuts and bolts to 20 ft-lb.

BREAK OFF STICK NUT

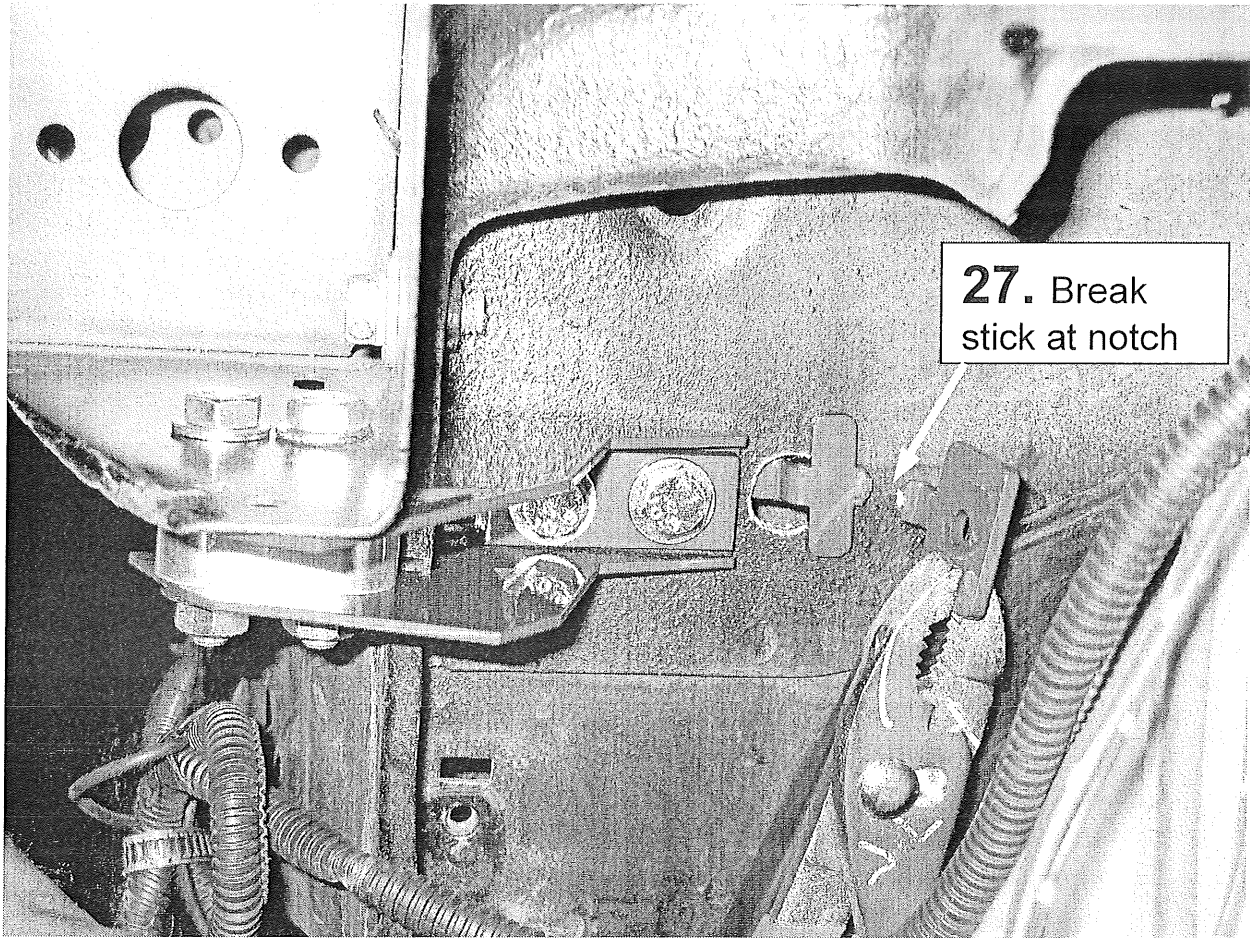

27. Break off the stick at the notch by bending it.

(Note: If you ever need to remove the Frame Locks and reinstall them, you can reuse the stick nuts even though they are broken off. To position them, simply use vice grips to grip the stick nuts.)

28. Repeat steps 14 – 27 to the right side of car.

DEMONSTRATE FRAME LOCKS TO FRIENDS

Demonstrating “before” and “after” rides

Why: It's fun, quick and easy to show yourself and friends the improvements Frame Locks makes to the car.

How:

- 1) **Remove the front fascia (plastic bumper cover)**
- 2) **Tie strap splash shield** - Secure the thin curved plastic splash guard in front of the wheel opening by tie strapping it so that the wind resistance won't push it back to the tire. If you don't tie strap it, the spinning tire will rub a wear into the splash guard.
- 3) **Before ride:** Loosen (do not need to remove) all the nuts and bolts
- 4) **Confirm loose to touch** - Be sure that the Frame Locks are loose by wiggling them with your hand. Sometimes the parts gets wedged and this affects the ride.
- 5) **Duct tape** - Place duct tape over the nuts and bolts and thru bolt piece to be sure they do not rattle loose when driving.
- 6) **Take it for a ride!!** - Be sure to drive safely and in control! ***For Handling:*** Try going to a large open and safe empty parking lot free of pedestrians and other cars. Drive straight at about 25-30 mph and make sharp, quick left to right steering inputs as if you are driving a slalom course. Make the turns abrupt enough that the tires are almost squealing. Pay attention to how quickly the car “points” after you turn your steering wheel. Remember the lag time it takes from the moment you turn the steering wheel until the car actually turns. Also pay attention to the amount of front roll and if the front end feels “heavy”. Now, drive straight at about 20 mph and make a sharp 90 degree right or left turn. Notice how much the car understeers. ***For Ride:*** Drive over pavement that is particularly damaged like patched up pot holes or damaged concrete. If you can drive over rail road tracks, that would be good too.
- 7) **After ride:** Torque down all the nuts and bolt. Go over the same roads as above and feel the difference!!

If you like the Frame Locks, be sure to tell your friends and post a review on your favorite car forum web site. If you post something, email the URL to manager@korbachperformance.com and you may win our next future product for free.

Thanks for your purchase!